

# 3000LP series



www.martekpower.com

## Single, Dual, Triple Output DC/DC Converter



### DESCRIPTIONS

The 3000LP series is a family of compact 25W to 30W, high performance DC/DC converters. These converters are specifically designed to provide the flexibility, power density, and reliability required to fulfill local power needs in applications ranging from telecom switch systems to portable instrumentation. 24 models operate over 2:1 input ranges of 9 to 18, 18 to 36 or 36 to 72 VDC; providing single, dual or triple output combinations of 5, 12, 15,  $\pm 5$ ,  $\pm 12$ ,  $\pm 15$ ,  $5\pm 12$  and  $5\pm 15$  VDC. All models are packaged in compact, low profile 3.0" X 2.56" X 0.4" metal cases.

### OUTPUT CHARACTERISTICS

	Min	Typ	Max	Unit/Comments
Output Voltage Accuracy				
Single & Dual Outputs			$\pm 1.0$	% <sup>1</sup>
Triple Outputs - Primary			$\pm 1.0$	% <sup>1</sup>
- Auxiliaries			$\pm 5.0$	% <sup>1</sup>
Output Voltage Adjustment			$\pm 5.0$	% <sup>1</sup> ; G Case Only
Voltage Balance:				
Dual Outputs			$\pm 2.0$	%; Equal Output Loads
Triple Outputs (Auxiliaries)			$\pm 100$	mV; Equal Output Loads
Minimum Load			10%	Full Load
Line Regulation				
Single Outputs			$\pm 0.5$	% <sup>2</sup>
Dual Outputs			$\pm 1.0$	% <sup>2</sup>
Triple Outputs - Primary			$\pm 0.2$	% <sup>2</sup>
- Auxiliaries			$\pm 5.0$	% <sup>2</sup>
Load Regulation				
Single Outputs			$\pm 0.5$	% <sup>3</sup>
Dual Outputs			$\pm 1.0$	% <sup>3</sup> ; Equal Loads
Triple Outputs - Primary			$\pm 1.0$	% <sup>3</sup>
- Auxiliaries			$\pm 2.0$	% <sup>3</sup> ; Equal Loads
Ripple/Noise				
5V Outputs		75		mV; p-p, Nom.Line FL, 20Mhz B.W. using 1 $\mu$ f bypass capacitor
12V and 15V Outputs		1		% of Vout
Short Circuit Protection				Continuous, Automatic Recovery
Transient Recovery Time		100		$\mu$ S to within 1% error band for 50% step load change
Temperature Coefficient			$\pm 0.01$	% per $^{\circ}$ C
Over Voltage Protection				See Model Selection Guide

Martek Power reserves the right to change specifications without notice.

### FEATURES

- 6 sided Continuous Shielding
- Synchronization and Output Trim
- Wide 2:1 Input Voltage Range
- Efficiency to 82%
- UL 1950 Approved
- CSA 22.9-950 Approved
- VDE / EN 60950 Approved
- >600,000 Hours MTBF

### INPUT CHARACTERISTICS

	Min	Typ	Max	Unit/Comments
Input Voltage Range				
12 VDC Input Models	9	12	18	VDC
24 VDC Input Models	18	24	36	VDC
48 VDC Input Models	36	48	72	VDC
Over Voltage Shutdown				
12 VDC Input Models		20		VDC
24 VDC Input Models		40		VDC
48 VDC Input Models		74		VDC
Remote ON / OFF Control				
Supply ON				5.5 VDC or Open Circuit
Supply OFF				0 VDC to 0.8 VDC
Logic Referenced to Negative Input				
Reverse Polarity Input Current			12	Amp
Input Filter				Pi Filter
Input Fuse Rating				See Model Selection Guide

### GENERAL CHARACTERISTICS

	Min	Typ	Max	Unit/Comments
Switching Frequency	100			kHz
Isolation Voltage	1000			VDC, 1 minute
Isolation Resistance	1000			Mohm, 500VDC
Isolation Capacitance		190		pF, 100kHz, 1Volt
MTBF (MIL-HBK-217F)				
Single and Dual Outputs	685			Thousand Hours, +25 $^{\circ}$ C, Ground Benign
Triple Outputs	570			Thousand Hours, +25 $^{\circ}$ C, Ground Benign

<sup>1</sup> = Output voltage at nominal line & FL

<sup>2</sup> = % Output voltage measured from min. input line to maximum

<sup>3</sup> = Output voltage measured from FL to 10% Load

## ENVIRONMENTAL SPECIFICATIONS

	Min	Typ	Max	Unit/Comments
Operating Temp. Range	-40		+75	°C; Ambient
Thermal Shutdown Protection		+95		°C; Case Temp.
Storage Temp. Range	-40		+125	°C
Relative Humidity			95	% Humidity; non-condensing
Cooling				Free-Air Convection

## PHYSICAL CHARACTERISTICS

	Unit/Comments
Case Size	2.56 X 3.0 X 0.4 inches (65.0 X 76.2 X 10.2 mm)
Case Material	Coated Metal with Non-Conductive Base
Shield Connection	
12V and 24V Input Models	Negative Input
48V Input Models	Positive Input
Flammability	UL94V-0
Weight	142 Grams

## OUTLINE DRAWING

### CASE G

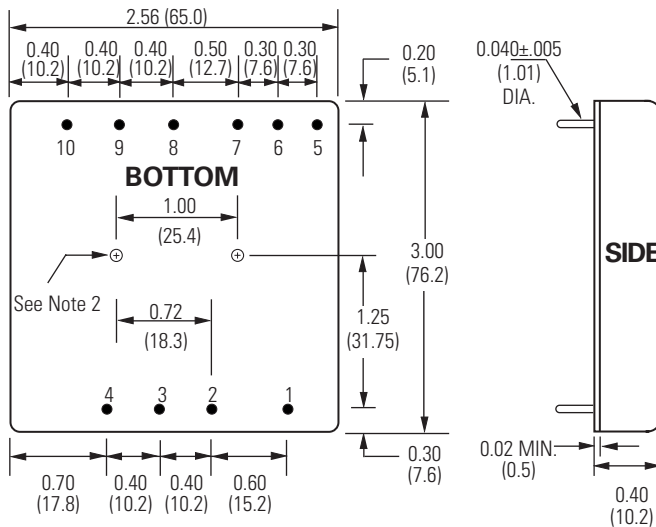

### PIN OUT CHART; CASE G

Pin	Single	Dual	Triple
1	Remote On/Off	Remote On/Off	Remote On/Off
2	+ Vin	+ Vin	+ Vin
3	- Vin	- Vin	- Vin
4	Sync	Sync	Sync
5	+Sense/Trim(Down)*	+ Vout	+ Vout (Aux)
6	Output Trim	Common	Common(Aux)
7	- Sense/Trim (Up)*	- Vout	- Vout
8	+ Vout*	Output Trim	+ Vout (Primary)
9	- Vout*	No Pin	- Vout (Primary)
10	No Pin	No Pin	Output Trim (Primary)

\* Connections for single output models without sensing or external trimming: For proper operation, externally connect Pin 5 (+Sense) to Pin 8 (+Vout) and Pin 7 (-Sense) to Pin 9 (-Vout)

### CASE G-1

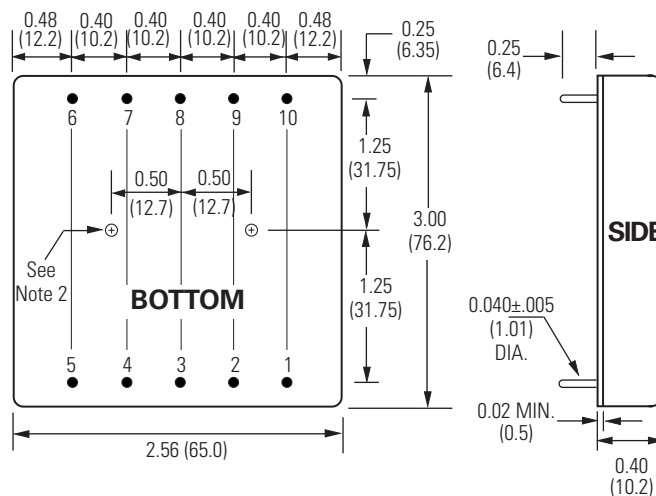

### PIN OUT CHART; CASE G-1

Pin	Single	Dual	Triple
1	Remote On/Off	Remote On/Off	Remote On/Off
2	No Pin	No Pin	No Pin
3	Input*	Input*	Input*
4	Input*	Input*	Input*
5	NC	NC	NC
6	NC	- Vout	- Vout (Aux)
7	NC	Output Common	+ Vout (Aux)
8	- Vout	Output Common	Output Common
9	+ Vout	+ Vout	+ Output (Primary)
10	Output Trim	Output Trim	Output Trim (Primary)

\* For 12V and 24V input models, Pin 3 is Minus (-) and Pin 4 is Plus (+). For 48V models, Pin 3 is (+) and Pin 4 is Minus (-).

### Notes:

- Unless otherwise specified dimensions are in inches (mm).  
Tolerances  
Inches                      mm  
X.XX = ±0.02              X.X = ±0.5  
X.XXX = ±0.010          X.XX = ±0.25
- Mounting inserts: 4-40 X .10 (2.5) Deep

All specifications are typical at nominal input, nominal load and 25° C unless otherwise specified. External, low ESR, 10 microfarad (minimum) capacitor across output is recommended for operation.

## How To ORDER

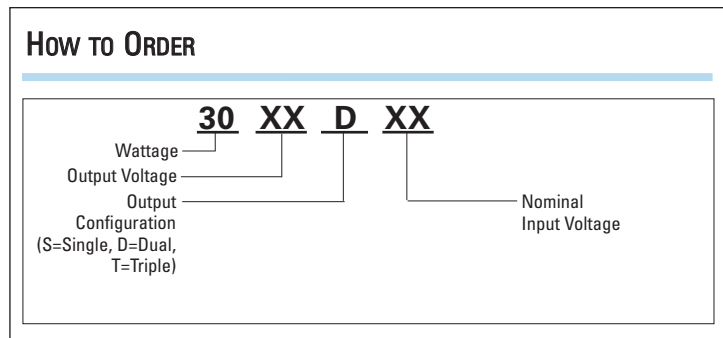

## MODEL SELECTION CHART

Model	Nominal Input Voltage (VDC)	Output Voltage (VDC)	Full Load Output Current (mA)	No Load Input Current (mA)	Full Load Input Current (mA)	Output Over Voltage (VDC)	Fuse (A)	Efficiency @ FL (%)
3005S12	12	5	5000	55	2670	6.5	5.0	78
3012S12	12	12	2000	55	2560	15.0	5.0	78
3015S12	12	15	1650	55	2640	18.0	5.0	78
3005D12	12	±5	±2500	55	2770	±6.5	5.0	75
3012D12	12	±12	±1000	55	2560	±15.0	5.0	78
3015D12	12	±15	±830	50	2670	±18.0	5.0	78
3005S24	24	5	6000	50	1560	6.5	3.0	80
3012S24	24	12	2500	50	1560	15.0	3.0	80
3015S24	24	15	2000	50	1560	18.0	3.0	80
3005D24	24	±5	±3000	50	1560	±6.5	3.0	80
3012D24	24	±12	±1250	50	1560	±15.0	3.0	80
3015D24	24	±15	±1000	50	1560	±18.0	3.0	80
3005S48	48	5	6000	50	762	6.5	1.5	82
3012S48	48	12	2500	40	762	15.0	1.5	82
3015S48	48	15	2000	40	762	18.0	1.5	82
3005D48	48	±5	±3000	40	762	±6.5	1.5	82
3012D48	48	±12	±1250	40	762	±15.0	1.5	82
3015D48	48	±15	±1000	40	760	±18.0	1.5	82
3005/12T12	12	5, ±12	2500, ±500	60	2610	6.5, ±15.0	5.0	78
3005/15T12	12	5, ±15	2500, ±400	60	2610	6.5, ±18.0	5.0	78
3005/12T24	24	5, ±12	3000, ±625	55	1560	6.5, ±15.0	3.0	80
3005/15T24	24	5, ±15	3000, ±500	55	1560	6.5, ±18.0	3.0	80
3005/12T48	48	5, ±12	3000, ±625	45	770	6.5, ±15.0	1.5	81
3005/15T48	48	5, ±15	3000, ±500	45	762	6.5, ±18.0	1.5	82